

Assembly instructions for double-pedestal table  
 Directives d'assemblage d'une table à base double  
 Instrucciones de montaje de una mesa con base doble

It is recommended that two people assemble the table.  
**Il est recommandé d'être deux personnes pour assembler la table.**  
 Se sugiere armar la mesa entre 2 personas.

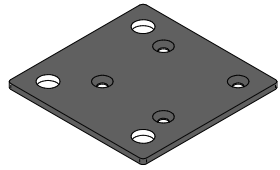

**a** 4 x

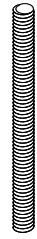

**b** 4 x

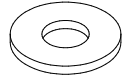

**c** 4 x



**d** 4 x



**e** 4 x

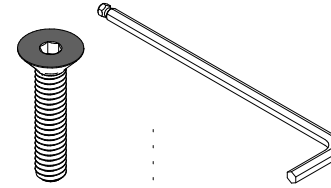

**f** 16 x

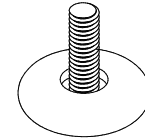

**h** 4 x



**i** 4 x

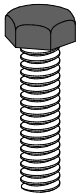

**j** 12 x



**k** 12 x

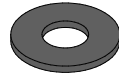

**l** 12 x

1/2"  
[ 12.7mm ]

**m** 1 x

7/16"  
[ 11.1mm ]

**n** 1 x

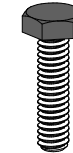

**o** 16 x



**p** 16 x



**q** 16 x

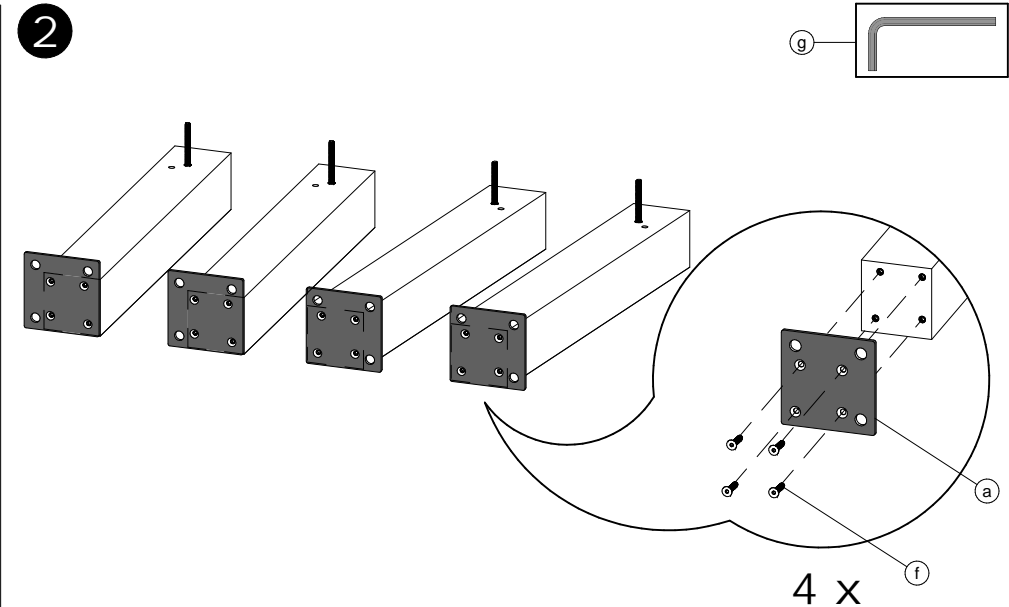
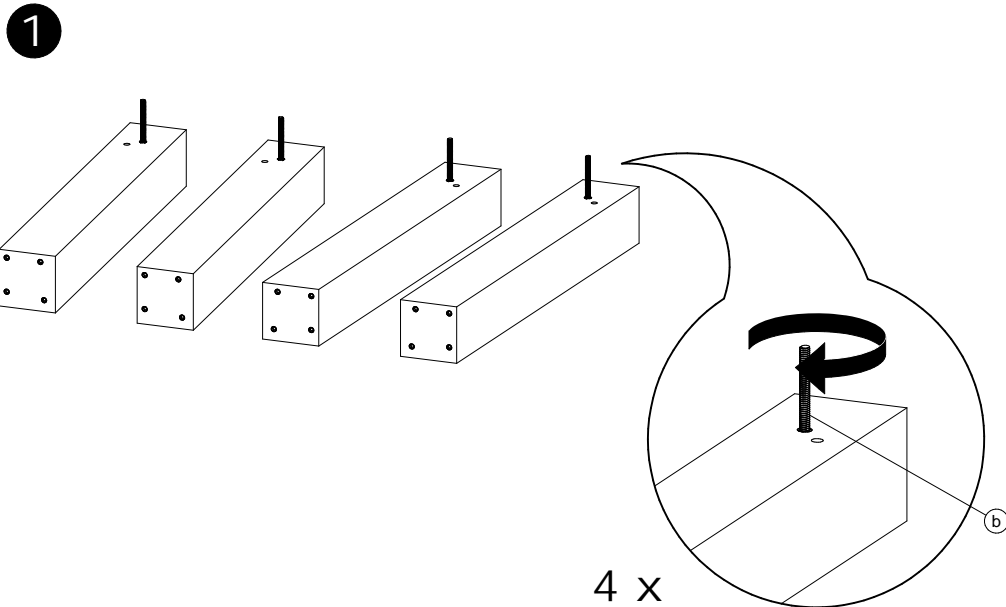

Assembly instructions for double-pedestal table  
 Directives d'assemblage d'une table à base double  
 Instrucciones de montaje de una mesa con base doble



3

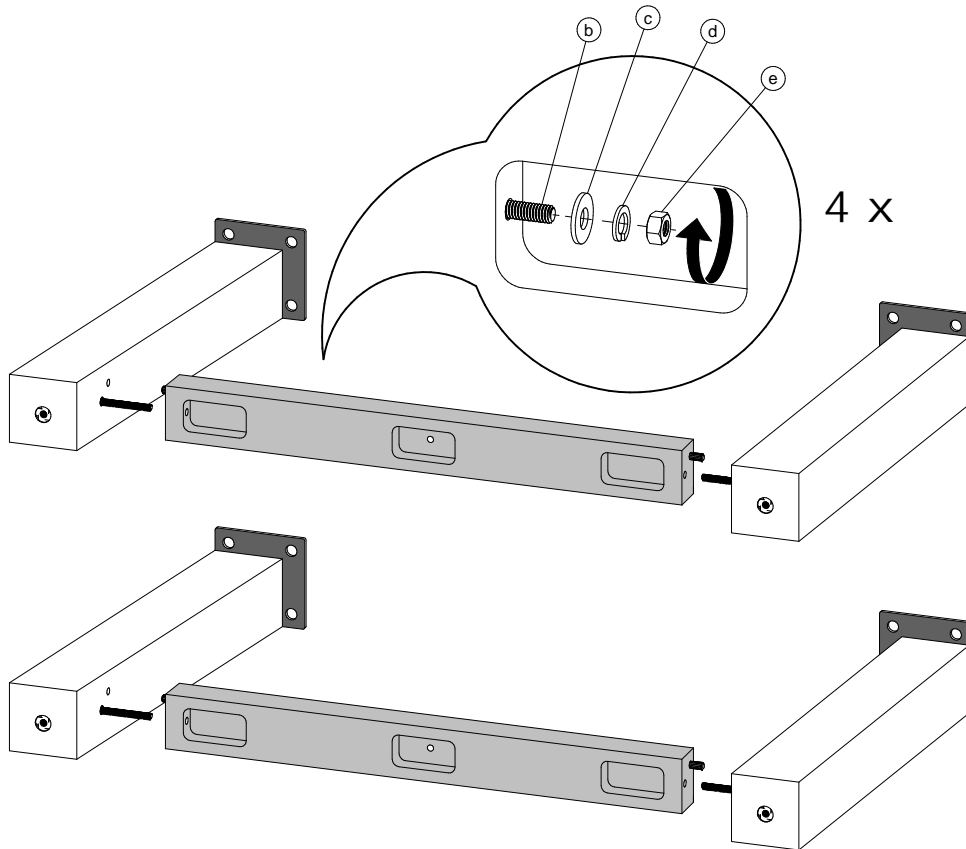
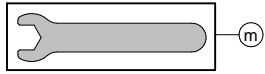

#3-4-5-6

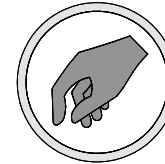

Begin by screwing the bolts  
 a few turns by hand.  
**Commencer par visser les boulons  
 en faisant quelques tours à la main.**  
 Comience a atornillar  
 los pernos a mano.

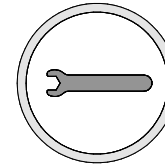

Screw the bolts with the wrench  
 provided, without over tightening.  
**Visser les boulons à l'aide de la  
 clé fournie sans trop serrer.**  
 Ajuste los pernos con la ayuda de la  
 llave suministrada, sin apretar demasiado.

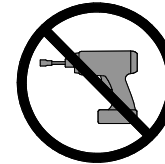

Do not use power tools or ratchet wrench.  
**Ne pas utiliser d'outils électriques  
 ni de clé à rochet.**  
 No utilice herramientas eléctricas  
 ni llave de trinquete.

4

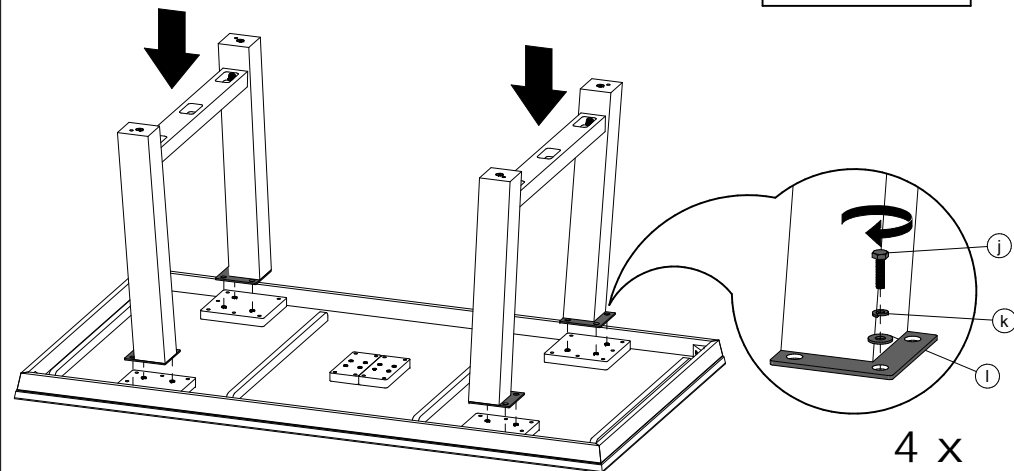
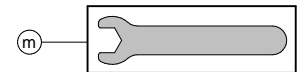

Assembly instructions for double-pedestal table  
 Directives d'assemblage d'une table à base double  
 Instrucciones de montaje de una mesa con base doble



Do not climb on the table.  
 Risk of serious injuries.  
**Ne pas monter sur la table.**  
**Risque de blessures graves.**  
 No treparse sobre la mesa.  
 Riesgo de herirse gravemente.

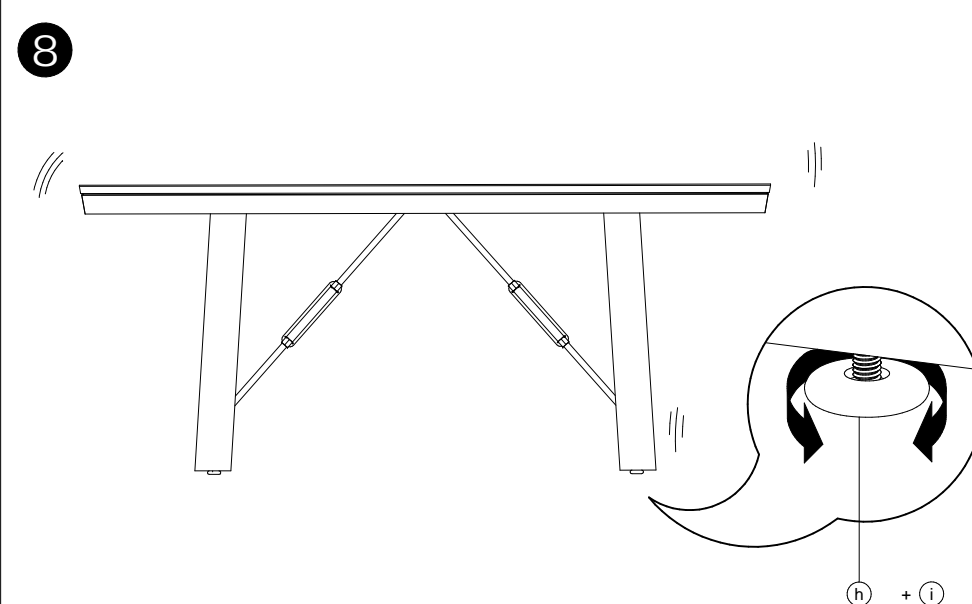
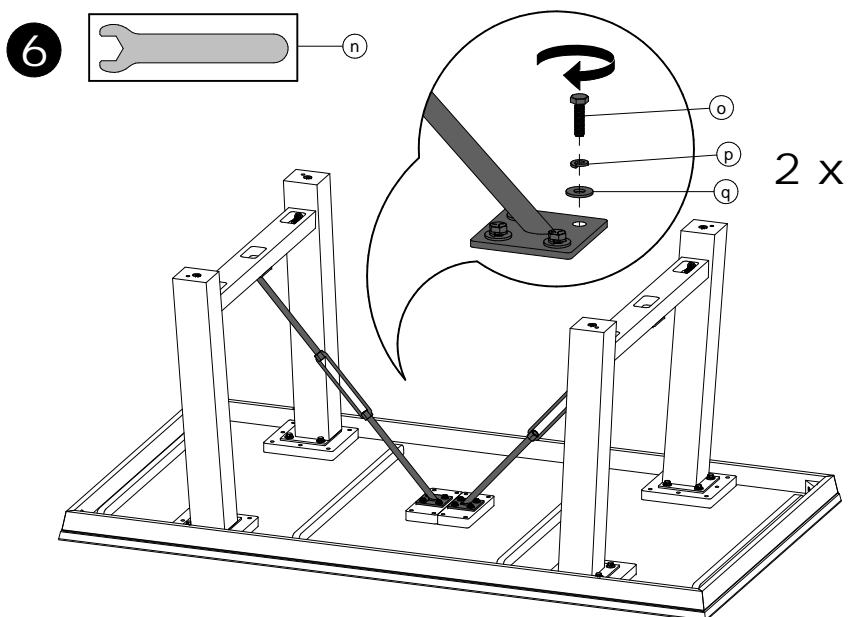
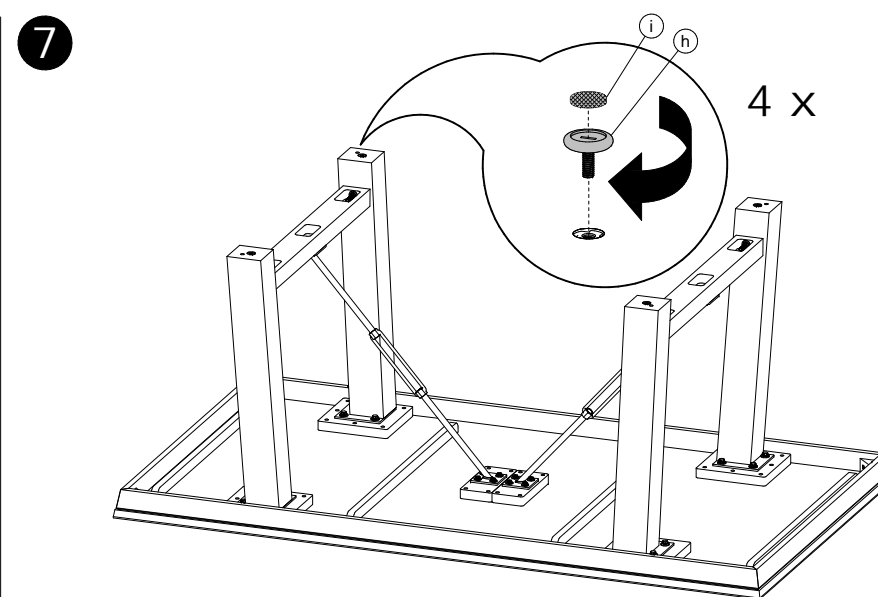
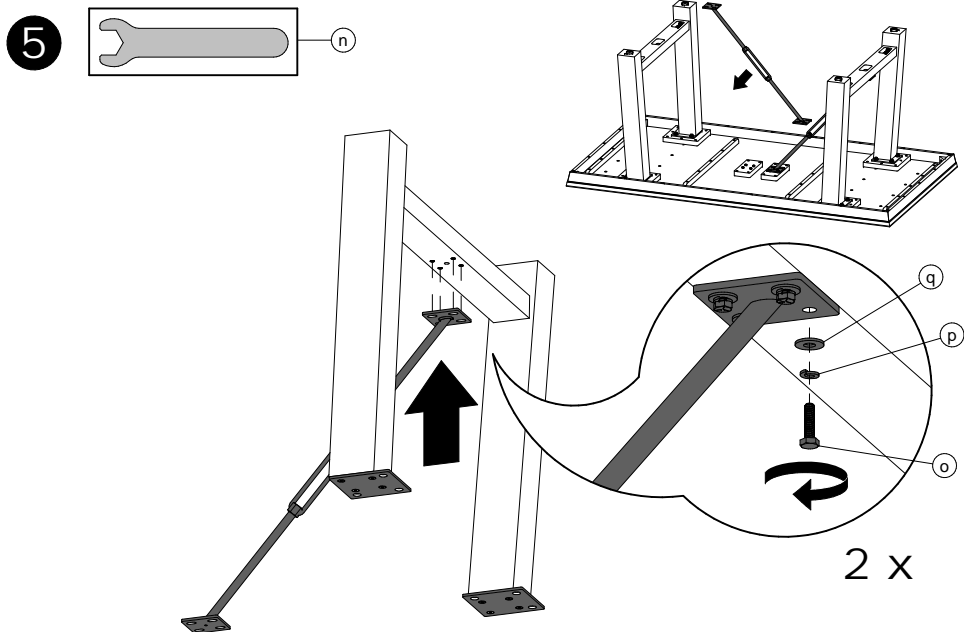



Renseignements pour circulation interne seulement  
 NE PAS INCLURE CETTE PAGE DANS LE SAC

CODE PRODUIT SAC:		QUI2SACZ100	
CODE PRODUIT INFO-CLIENT:		FOP2INZTAB-1100	
REVISION:		P02	
NO	NOM	DESCRIPTION	QTE
<b>1</b>	<b>QUI2SACZ100-SK1</b>	<b>SOUS-KIT #1</b>	<b>1</b>
1.1	FOACLEZALLEN4MMX3 1-2-B	CLE HEX. M4 X 3 1/2" BALL END	1
1.2	FOAVISZ1-4-20X1 1-4FL BL	VIS FRAISEE 1/4-20 X 1 1/4" NOIR	16
<b>2</b>	<b>QUI2SACZ100-SK2</b>	<b>SOUS-KIT #2</b>	<b>1</b>
2.1	FOAVISZBH5-16-18X1 BL	BOULON HEX. NOIR 5/16-18 X 1"	12
2.2	FOAVISZLW 5-16 BL	RONDELLE RESSORT NOIRE BOULON 5/16"	12
2.3	FOAVISZWAS3-8H 5-16B BL	RONDELLE NOIRE ID3/8"-BOULON 5/16"	12
<b>3</b>	<b>QUI2SACZ100-SK3</b>	<b>SOUS-KIT #3</b>	<b>1</b>
3.1	FOACLEZBOULON 7-16	CLE 7/16" BOULON 1/4-20	1
3.2	FOAVISZBH1-4-20X1 BL	BOULON HEX. NOIR 1/4-20 X 1"	16
3.3	FOAVISZLW 1-4 BL	RONDELLE RESSORT NOIRE BOULON 1/4"	16
3.4	FOAVISZWAS5-16H 1-4B BL	RONDELLE NOIRE ID5/16"-BOULON 1/4"	16
<b>4</b>	<b>QUI2SACZ100-SK4</b>	<b>SOUS-KIT #4</b>	<b>1</b>
4.1	FOACLEZBOULON 1-2	CLE 1/2" BOULON 5/16-18	1
4.2	FOAVISZHN5-16-18	ECROU HEX. 5/16-18	4
4.3	FOAVISZLW 5-16	RONDELLE RESSORT BOULON 5/16"	4
4.4	FOAVISZTF5-16-18X4	TIGE FILETEE 5/16-18 X 4"	4
4.5	FOAVISZWAS3-8H 5-16B	RONDELLE ID3/8"-BOULON 5/16"	4
4.6	QUIACCCZ00701C	NIVELEUR	4
4.7	QUIACCCZFUTREV23125	FEUTRE COLLANT DIA. 1"	4
<b>5</b>	<b>QUIACCPPLAQUET-IMP</b>	<b>PLAQUE</b>	<b>4</b>

