

Assembly instructions for double pedestal table
 Principe d'assemblage d'une table à base double
 Procedimiento de ensamblaje de una mesa con base doble

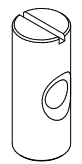

a 12 x

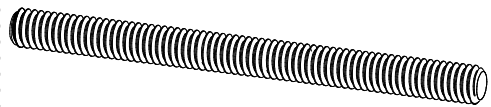

b 12 x

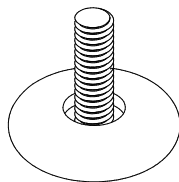

c 4 x

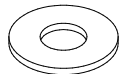

d 6 x



e 12 x



f 18 x

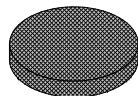

g 4 x

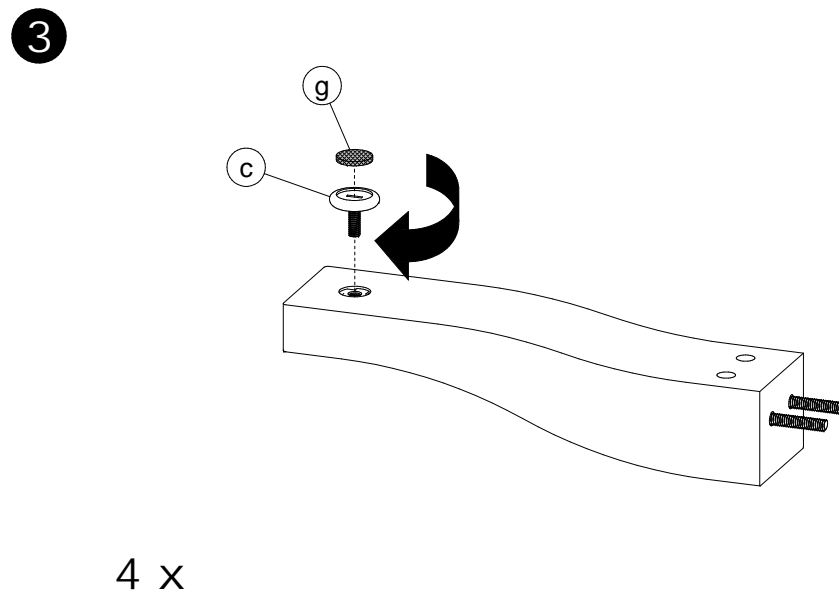
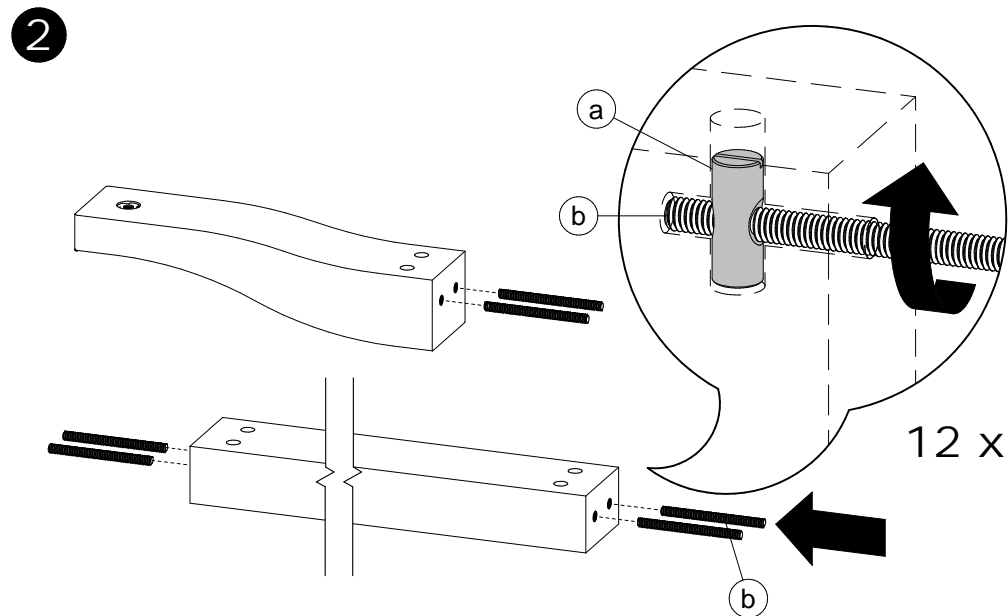
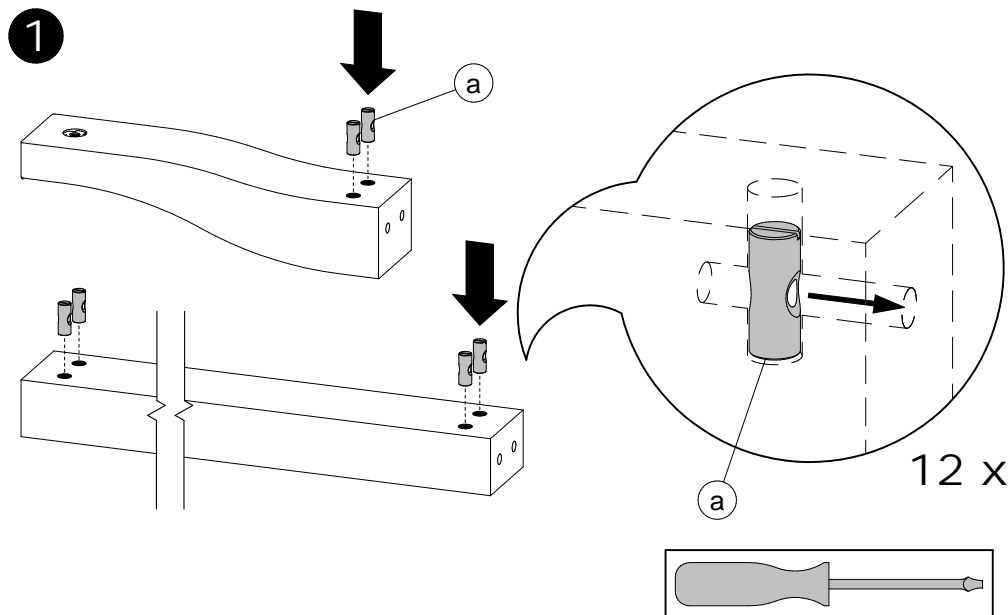

Assembly instructions for double pedestal table
 Principe d'assemblage d'une table à base double
 Procedimiento de ensamblaje de una mesa con base doble

 Do not climb on the table.
 Risk of serious injury.
Ne pas monter sur la table.
Risque de blessures graves.
 No se trepe sobre la mesa.
 Riesgo de herirse gravemente.

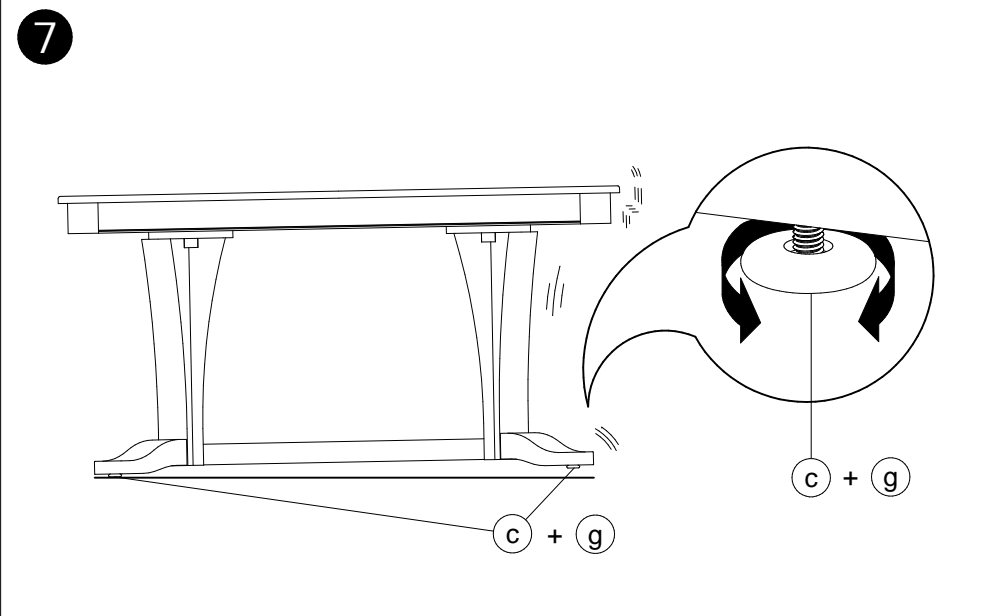
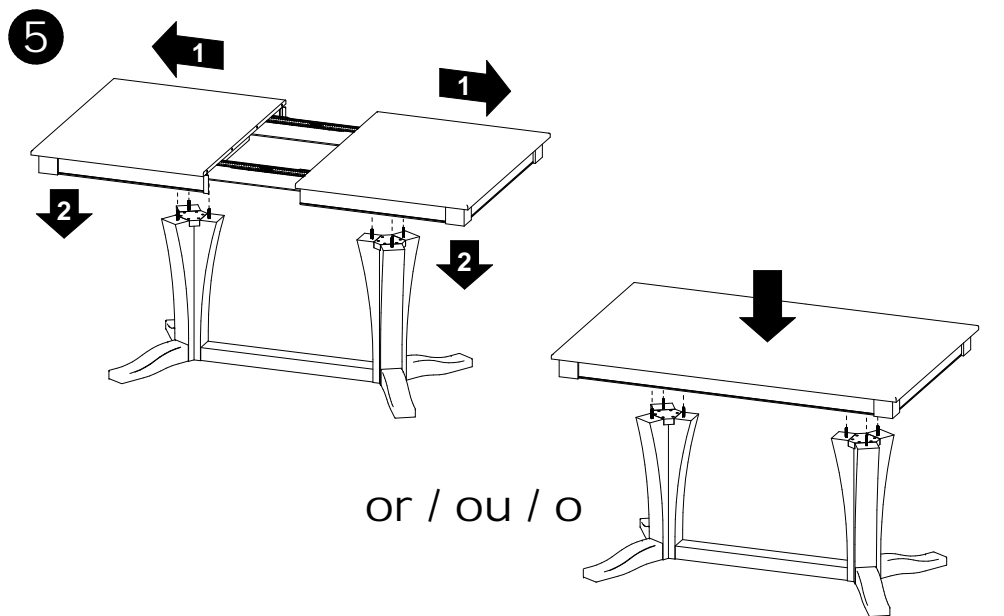
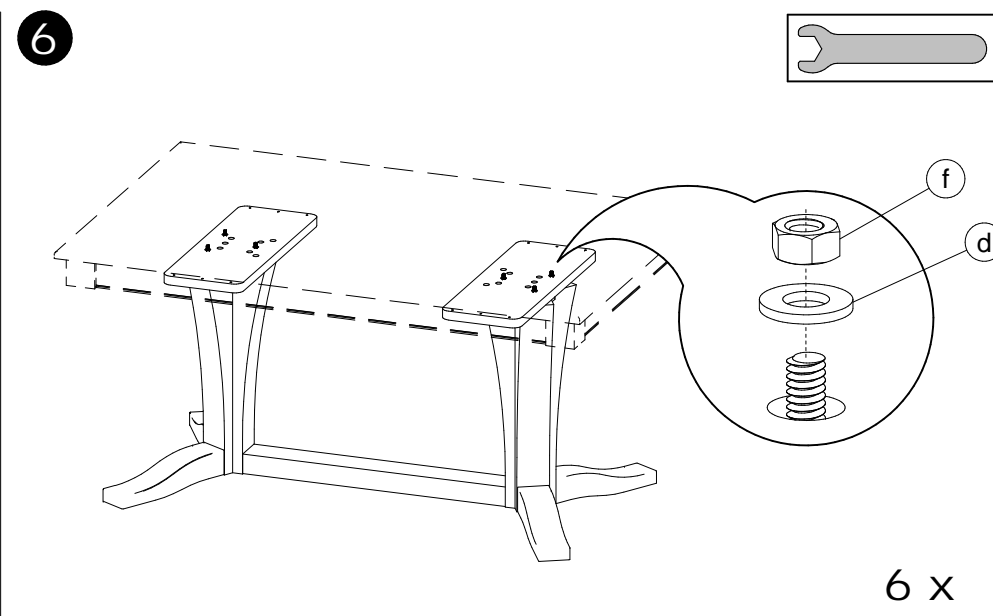
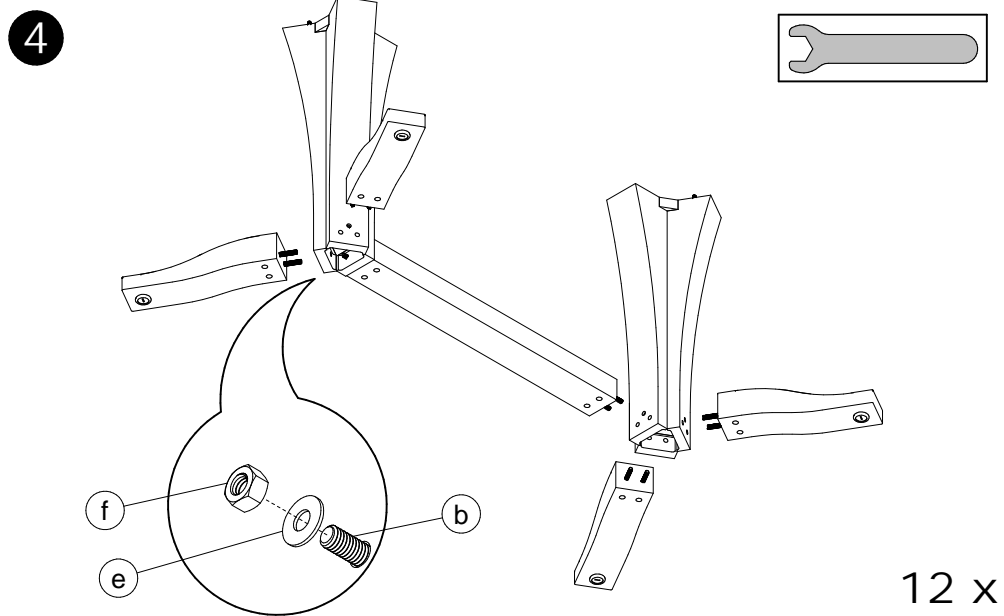

How to use and adjust the table latch

Utilisation et ajustement du loquet de table

Utilización y ajuste del pestillo de mesa

- 1** · Unlock all the latches:
 a) Push down the lever so it is vertical. b) Release the triangular bolt from the latch plate.
 Now you can open your table.
- **Débarrer tous les loquets:**
 a) Descendre le levier en position verticale. b) Dégager le pêne triangulaire de la gâche.
 Vous pouvez maintenant ouvrir votre table.
- Abrir todos los pestillos:
 a) Bajar el palanca en posición vertical. b) Liberar el cerrojo triangular de la placa.
 Usted puede ahora abrir su mesa.

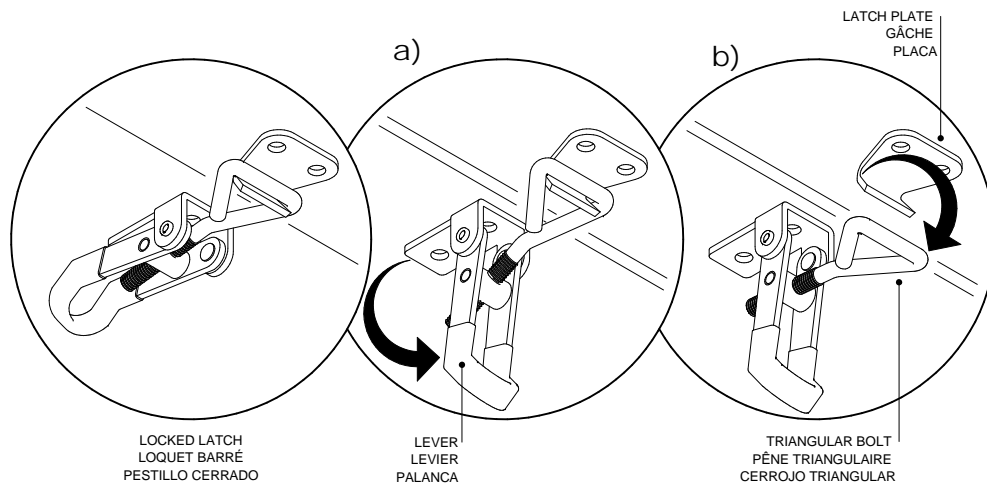

- 2** · Close the table and lock all the latches:
 a) Rotate the triangular bolt towards the latch plate. b) Pull up the lever to a horizontal position.
 If the latch does not close well, do not force the lever and follow the next step.
- **Refermer la table et barrer tous les loquets:**
 a) Pivoter le pêne triangulaire vers la gâche. b) Remonter le levier en position horizontale.
 Si le loquet ne ferme pas bien, ne pas forcer le levier et suivre l'étape suivante.
- Cerrar la mesa y asegurar todos los pestillos:
 a) Subir el cerrojo triangular hacia el placa. b) Elevar la palanca en posición horizontal.
 Si el pestillo no se cierra bien, no forzar el palanca y seguir la etapa siguiente.

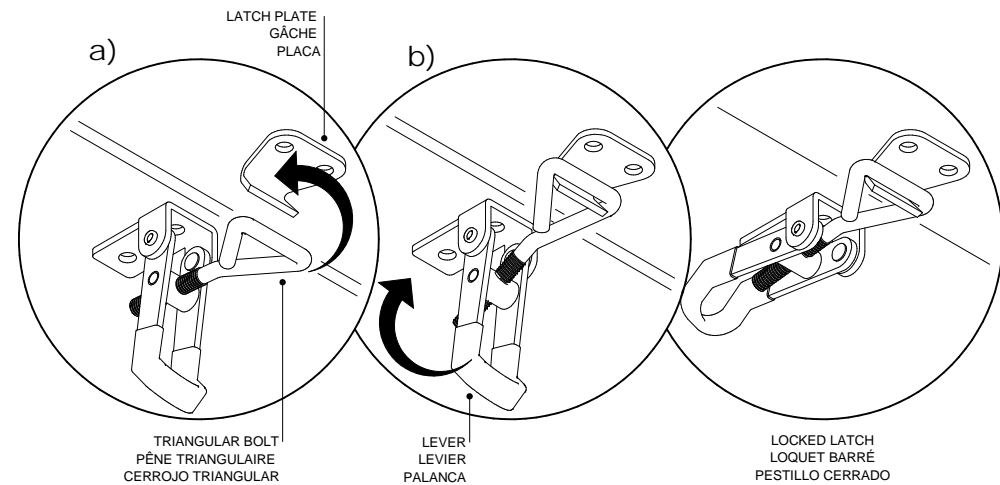

- 3** · Never force the lever to lock the latch.
 Screw or unscrew the triangular bolt to adjust the assembly joint.
- **Ne jamais forcer le levier pour barrer le loquet.**
 Visser ou dévisser le pêne triangulaire pour ajuster le joint de fermeture.
- Nunca forzar el palanca para bloquear el pestillo.
 Atornillar o destornillar el cerrojo triangular para ajustar la juntura del ensamblaje

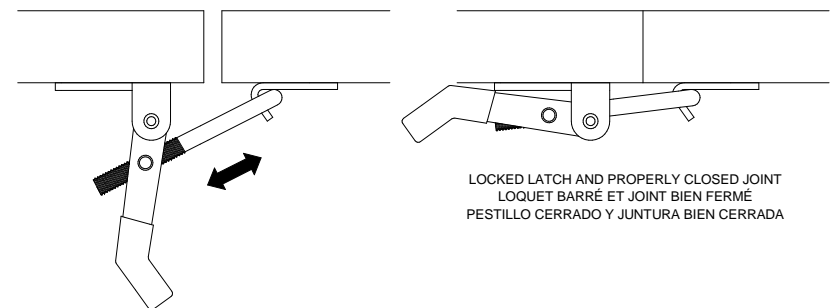
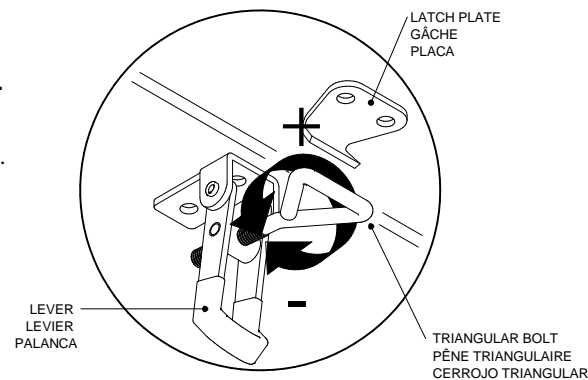

Renseignements pour circulation interne seulement
 NE PAS INCLURE CETTE PAGE DANS LE SAC

CODE PRODUIT SAC:	QUI2SACZ079		
CODE PRODUIT INFO-CLIENT:	FOP2INZTAB-1079		
REVISION:	P03		
NO	NOM	DESCRIPTION	QTÉ
1	FOAVISZCD5-16-18X30MM	BARIL ECROU 5/16-18 X 30mm	12
2	FOAVISZHN5-16-18	ECROU HEX. 5/16-18	18
3	FOAVISZTF5-16-18X3 1-2	TIGE FILETEE 5/16-18 X 3 1/2"	12
4	FOAVISZWAS-M8	RONDELLE METRIQUE M8	12
5	FOAVISZWAS3-8H 5-16B	RONDELLE ID3/8"-BOULON 5/16"	6
6	QUIACCZ00701C	NIVELEUR	4
7	QUIACCZFUTREV23125	FEUTRE COLLANT DIA. 1"	4

