

**Assembly method for table with two bridges and a table top**  
**Principe d'assemblage d'une table à deux ponts et un dessus**  
**Instrucciones de ensamblaje de una mesa con dos puentes y una parte superior**

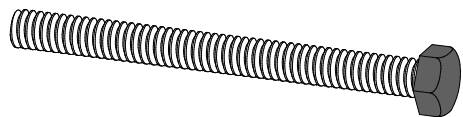

**a** 6 x



**b** 10 x

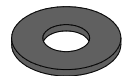

**c** 10 x

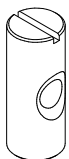

**d** 6 x

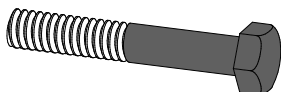

**e** 4 x

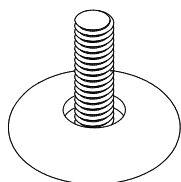

**f** 4 x

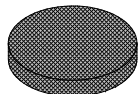

**g** 20 x

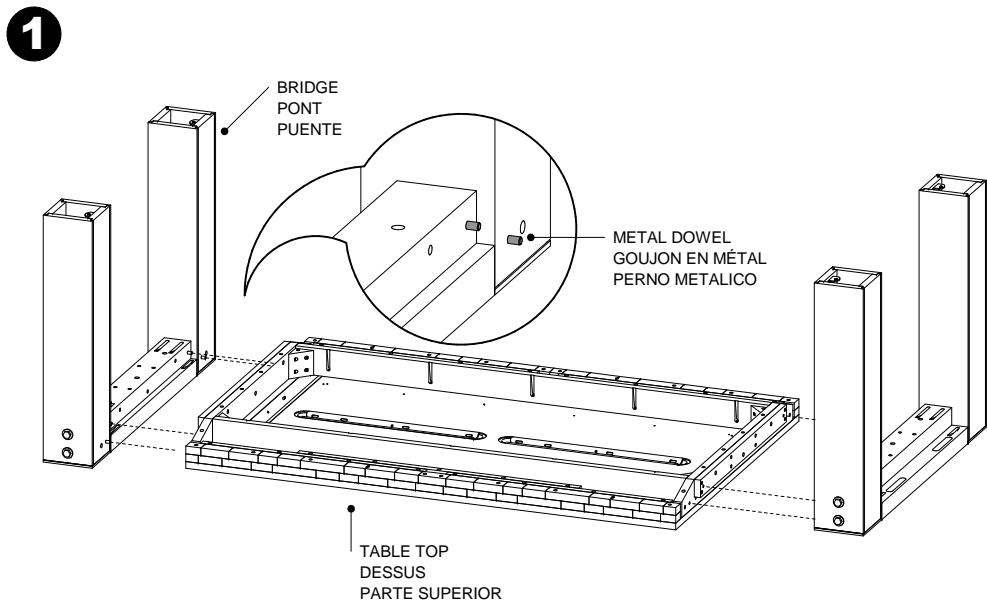

**2**

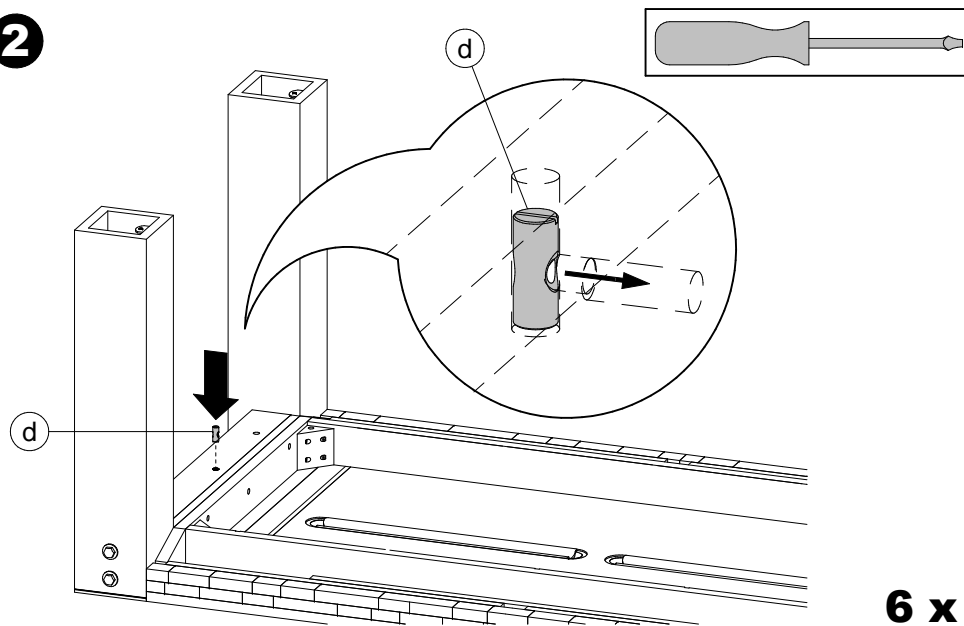

**3**

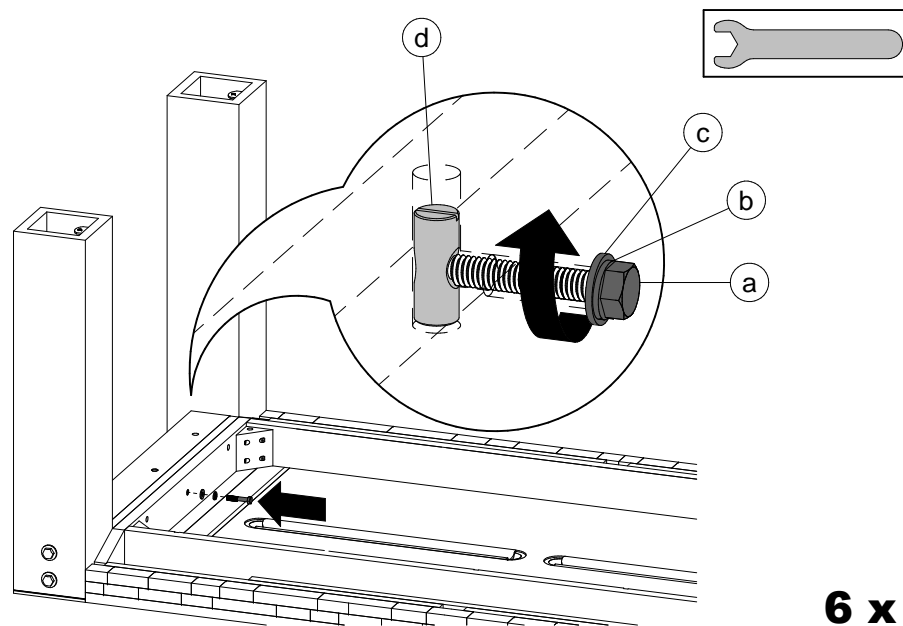

**Assembly method for table with two bridges and a table top**  
**Principe d'assemblage d'une table à deux ponts et un dessus**  
**Instrucciones de ensamblaje de una mesa con dos puentes y una parte superior**



Do not climb on the table.  
Risk of serious injuries.  
**Ne pas monter sur la table.**  
**Risque de blessures graves.**  
No treparse sobre la mesa.  
Riesgo de herirse gravemente.

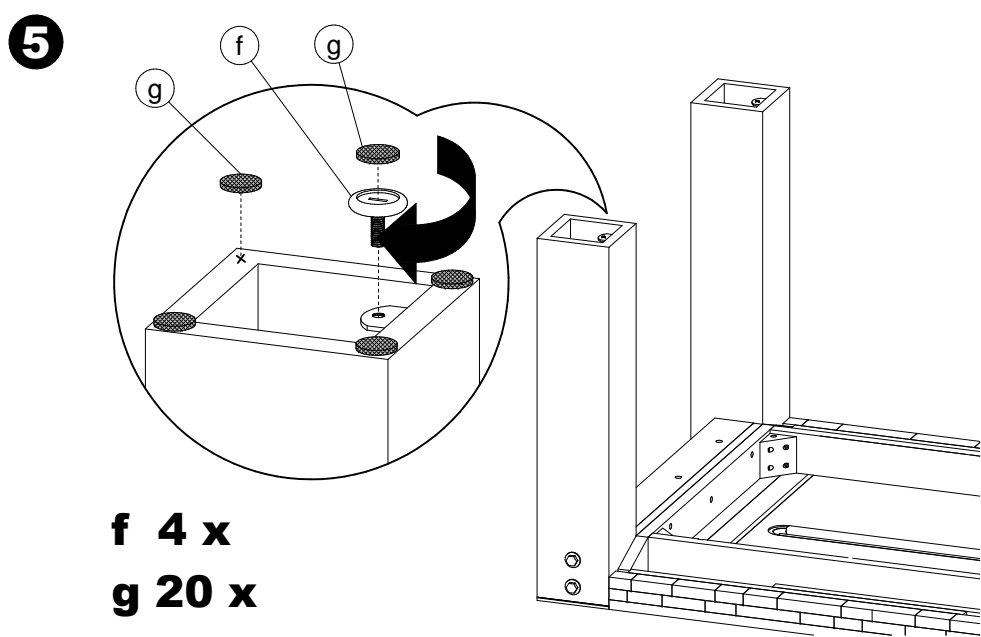
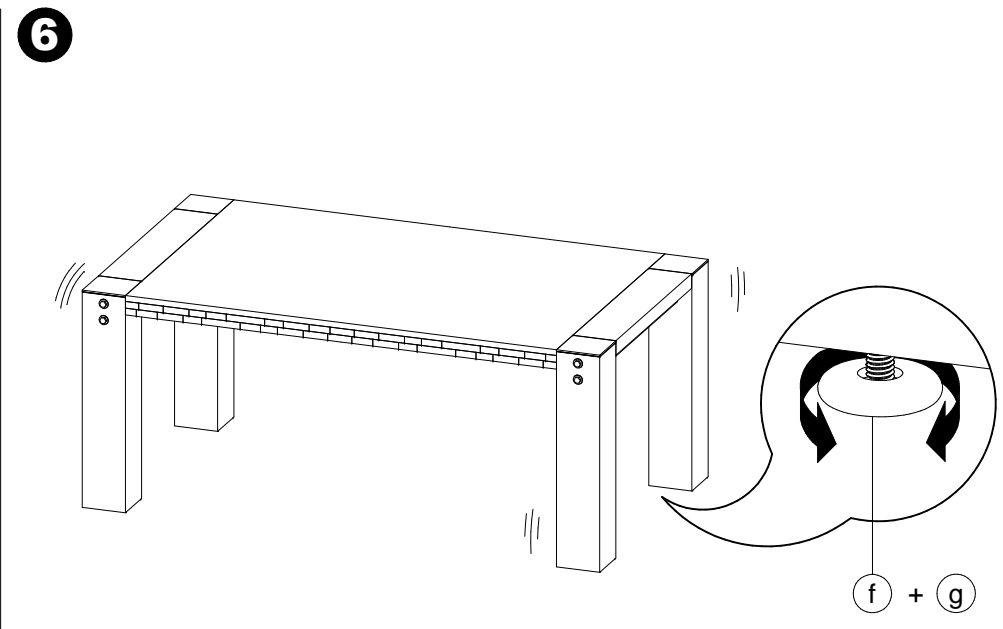
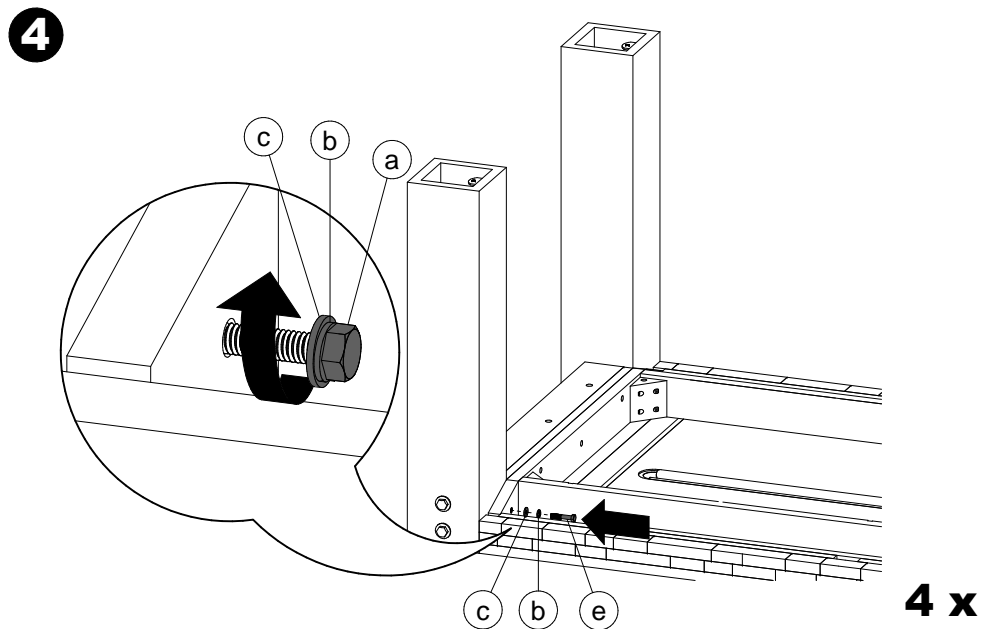

CODE PRODUIT SAC:	QUI2SACZ090	
CODE PRODUIT INFO-CLIENT:	FOP2INZTAB-1090	
REVISION:	P01	
<b>DESCRIPTION</b>	<b>NOM</b>	<b>QTÉ</b>
BOULON HEX. 5/16-18 X 2" NOIR	FOAVISZBH5-16-18X2 BL	4
BOULON HEX. 5/16-18 X 3 1/2" NOIR	FOAVISZBH5-16-18X31-2BL	6
BARREL NUT 5/16-18 X 30MM	FOAVISZCD5-16-18X30MM	6
LOCK WASHER 5/16 NOIR	FOAVISZLW 5-16 BL	10
WASHER 7/16H 3/8B NOIR	FOAVISZWAS7-16H 3-8B BL	10
NIVELEUR DIA1 3/8"; 5/16-18X7/8"	QUIACCZ00701C	4
FEUTRE COLLANT DIA. 1"	QUIACCZFEUTREV23125	20

