

Assembly method for a table with legs

Principe d'assemblage d'une table à cinq pattes

Instrucciones de ensamblaje de una mesa con cinco patas

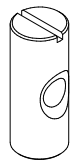

a 4 x

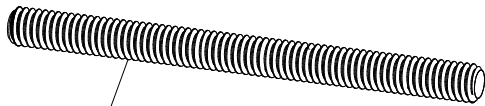

b 4 x

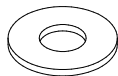

c 6 x



d 6 x



e 6 x

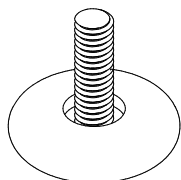

f 1 x

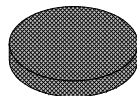

g 5 x

1

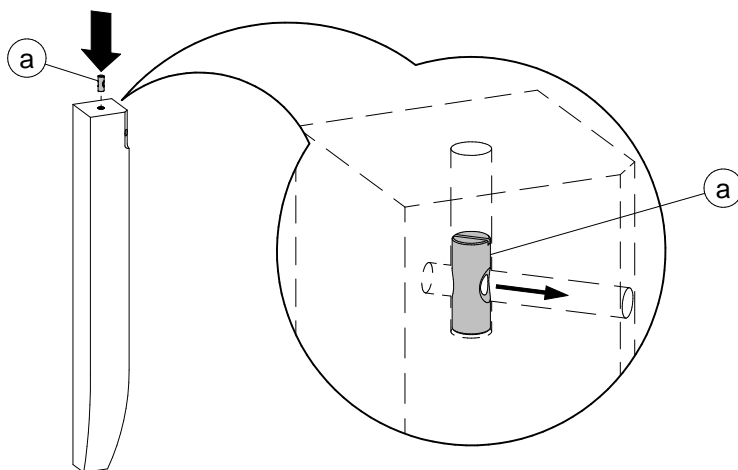
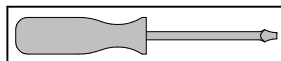

4 x

2

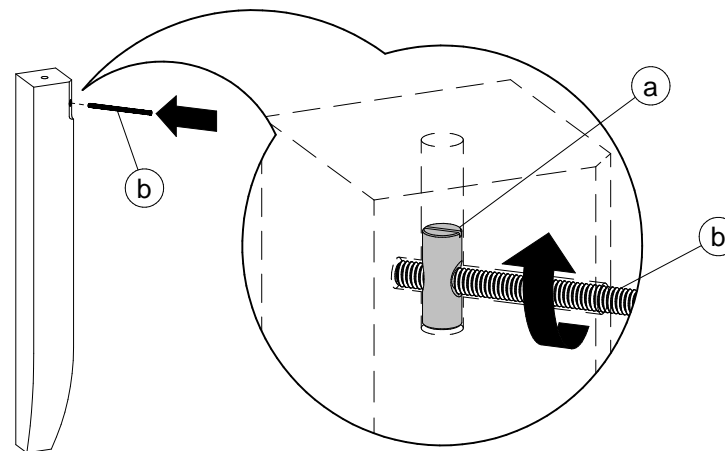

4 x

3

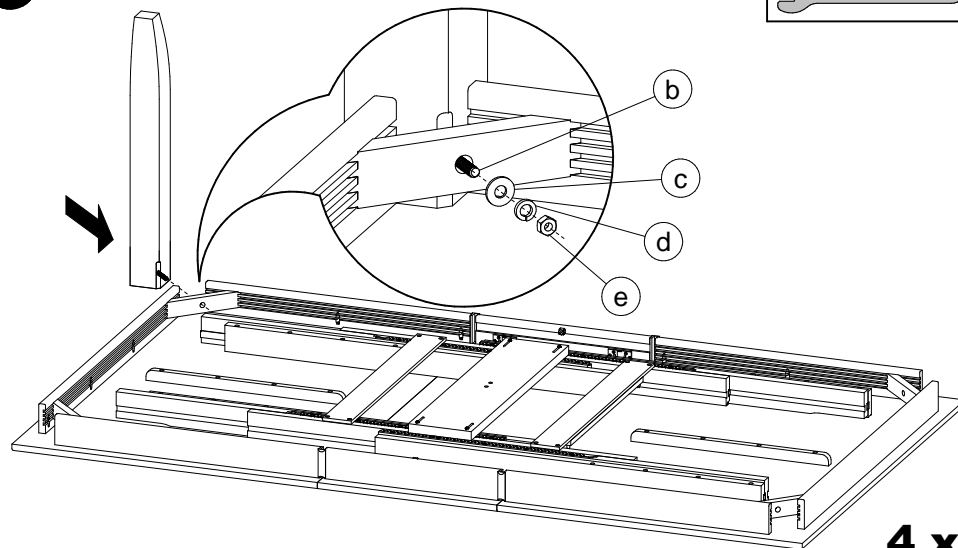
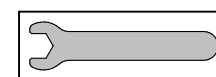

4 x

Assembly method for a table with legs
Principe d'assemblage d'une table à cinq pattes
Instrucciones de ensamblaje de una mesa con cinco patas



Do not climb on the table.
 Risk of serious injuries.
Ne pas monter sur la table.
Risque de blessures graves.
 No treparse sobre la mesa.
 Riesgo de herirse gravemente.

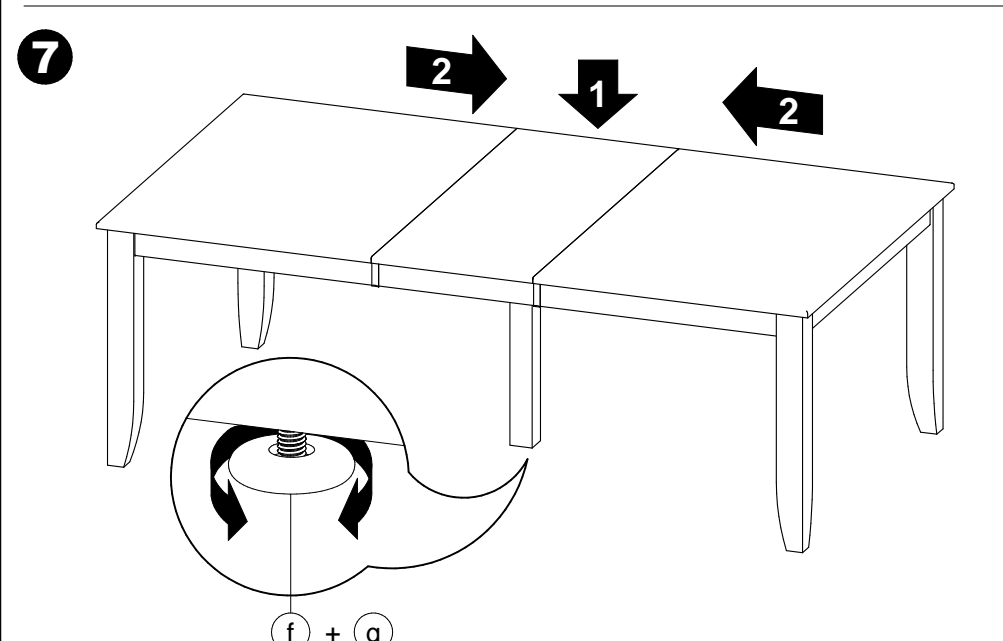
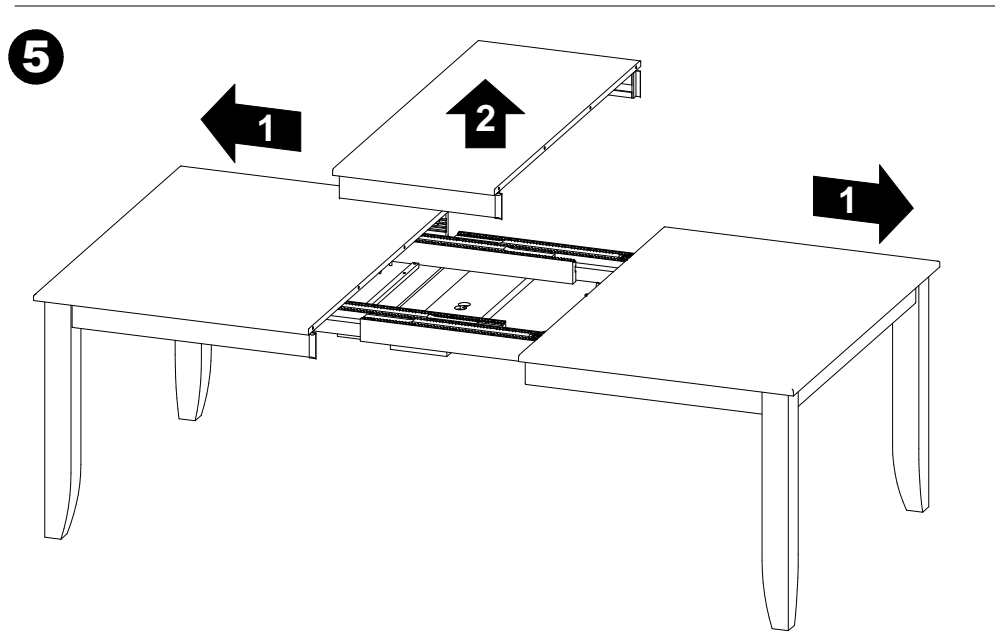
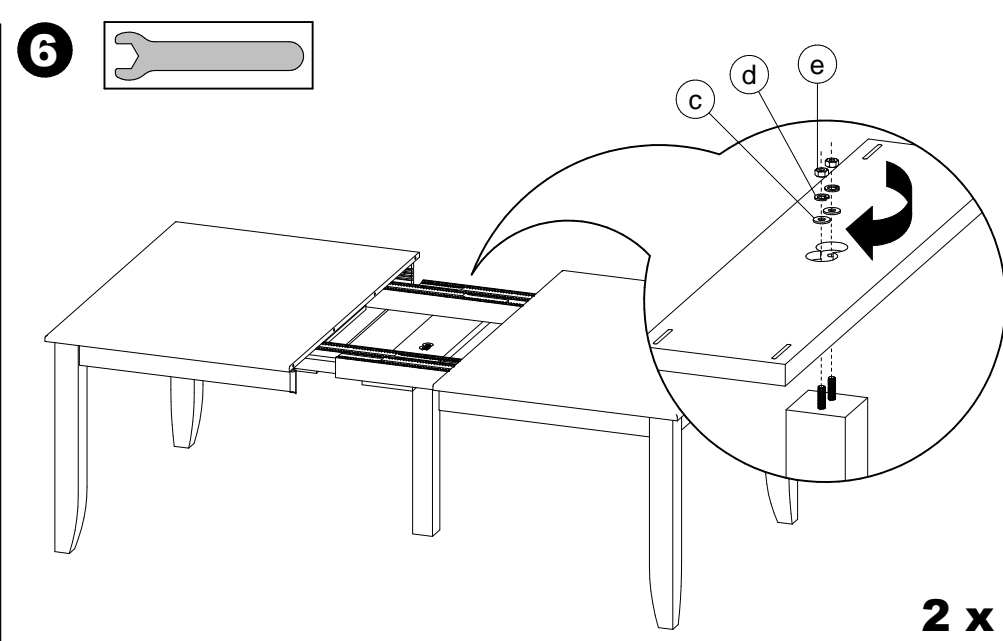
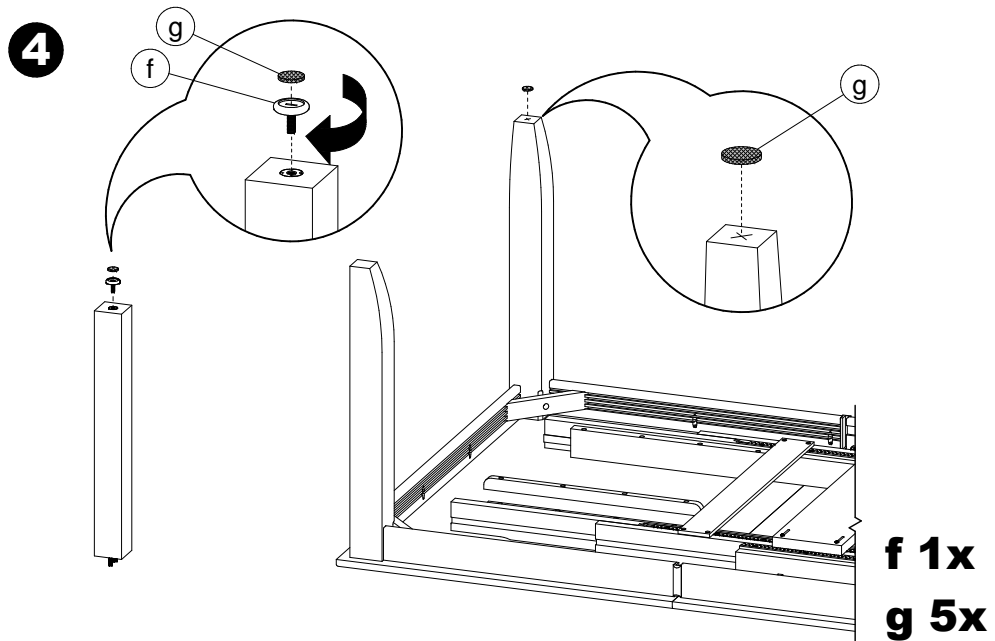

CODE PRODUIT SAC:	QUI2SACZ078	
CODE PRODUIT INFO-CLIENT:	FOP2INZTAB-1078	
REVISION:	P01	
DESCRIPTION	NOM	QTÉ
BARREL NUT 5/16-18 X 30MM	FOAVISZCD5-16-18X30MM	4
ECROU 5/16-18 ZINC	FOAVISZHN5-16-18	6
LOCK WASHER 5/16 ZINC	FOAVISZLW 5-16	6
TIGE FILETÉE 5/16-18 X 4 3/4"	FOAVISZTF5-16-18X4 3-4	4
WASHER 5/16 (STD) ZINC	FOAVISZWAS3-8H 5-16B	6
NIVELEUR DIA1 3/8"; 5/16-18X7/8"	QUIACCZ00701C	1
FEUTRE COLLANT DIA. 1"	QUIACCZFEUTREV23125	5