

# Assembly method for a table with legs

## Principe d'assemblage d'une table à pattes

### Instrucciones de ensamblaje de una mesa con patas

 Do not climb on the table.  
 Risk of serious injuries.  
**Ne pas monter sur la table.**  
**Risque de blessures graves.**  
 No treparse sobre la mesa.  
 Riesgo de herirse gravemente.

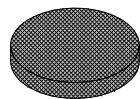

**a** 4 x

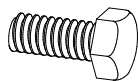

**b** 16 x



**c** 16 x



**d** 16 x

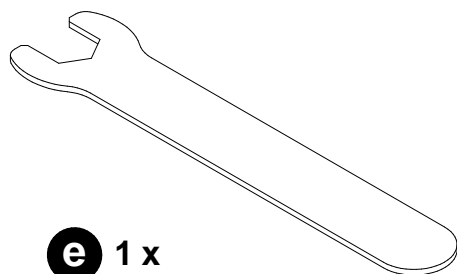

**e** 1 x

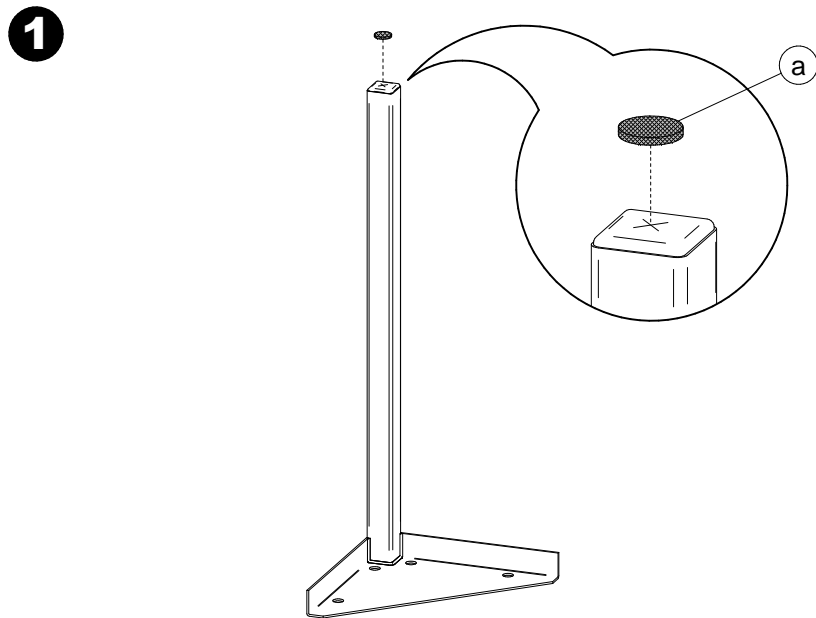

**4 x**

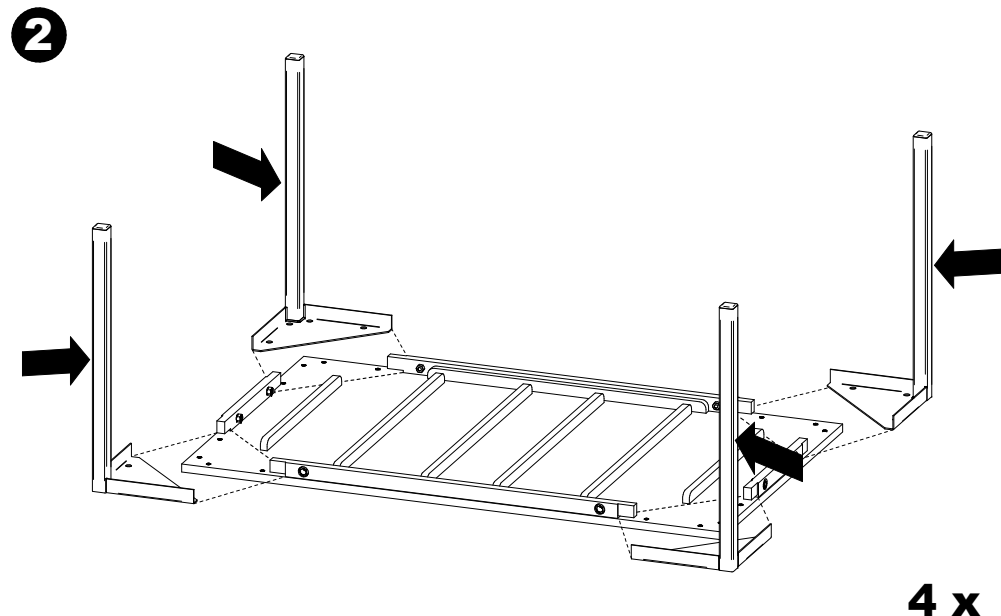

**4 x**

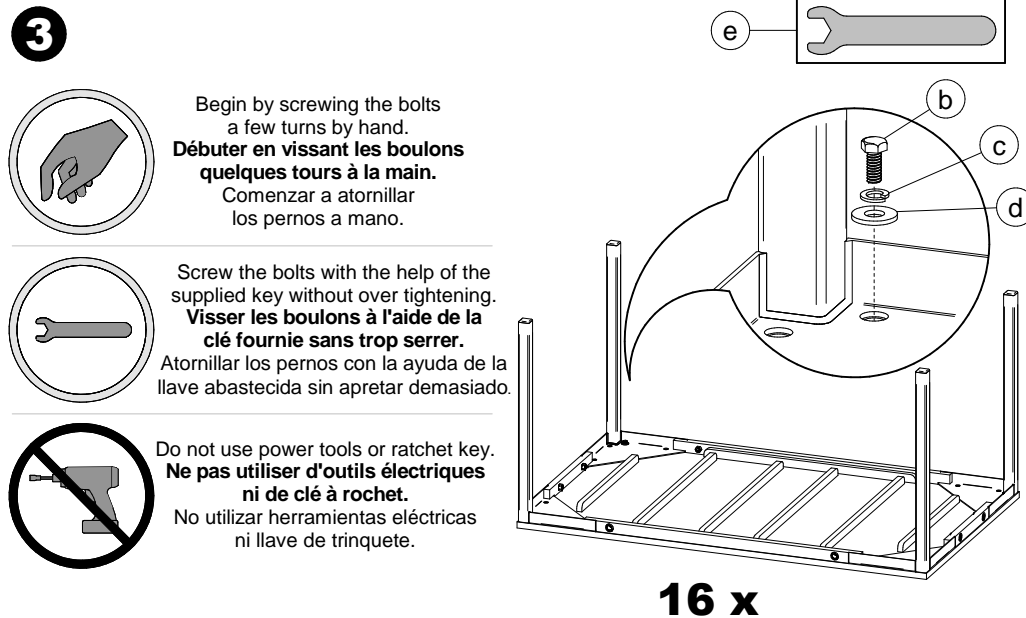

**16 x**

CODE PRODUIT SAC:	QUI2SACZ066	
CODE PRODUIT INFO-CLIENT:	FOP2INZTAB-1066	
REVISION:	P01	
<b>DESCRIPTION</b>	<b>NOM</b>	<b>QTÉ</b>
CLÉ 1/2" POUR BOLTS 5/16"	FOACLEZBOULON 1-2	1
BOULON HEX. 5/16-18 X 3/4"	FOAVISZBH5-16-18X3-4	16
LOCK WASHER 5/16 ZINC	FOAVISZLW 5-16	16
WASHER 5/16 (STD) ZINC	FOAVISZWAS3-8H 5-16B	16
FEUTRE COLLANT DIA. 1"	QUIACCZFEUTREV23125	4