

Assembly method for a table with legs

Principe d'assemblage d'une table à pattes

Instrucciones de ensamblaje de una mesa con patas

It is recommended to be two people to assemble the table.
 Il est suggéré d'être à deux pour assembler la table.
 Se sugiere 2 personas para ensamblar la mesa.

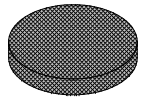

a 4 x

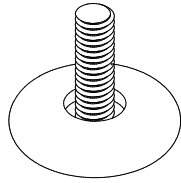

b 4 x

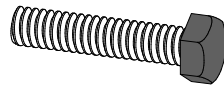

c 16 x



d 16 x

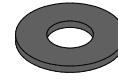

e 16 x

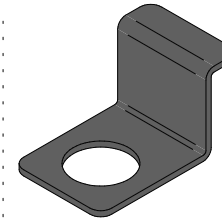

f 8 x

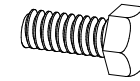

g 8 x



h 8 x

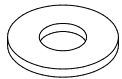

i 8 x

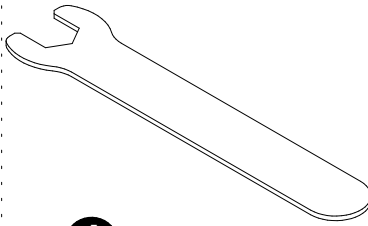

j 1 x

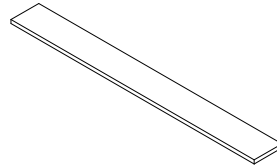

k 8 x

1

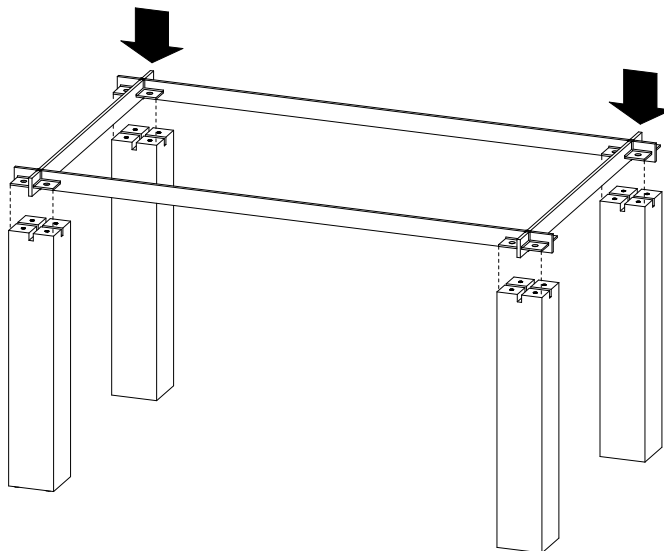

2

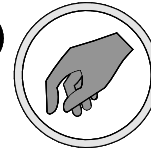

Begin by screwing the bolts a few turns by hand.
Débuter en vissant les boulons quelques tours à la main.
 Comenzar a atornillar los pernos a mano.

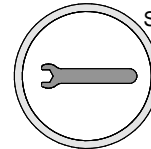

Screw the bolts with the help of the supplied hardware without overtightening.
Visser les boulons à l'aide de la clé fournie sans trop serrer.
 Atornillar los pernos con la ayuda de la llave abastecida sin apretar demasiado.



Do not use power tools or ratchet key.
Ne pas utiliser d'outils électriques ni de clé à rochet.
 No utilizar herramientas eléctricas ni llave de trinquete.

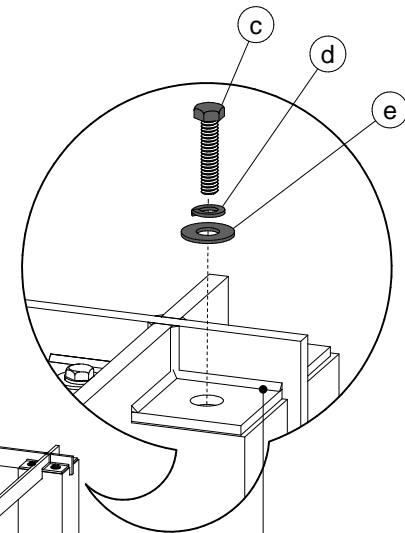
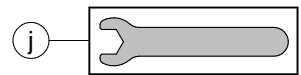

WELDS ON TOP
 SOUDURES AU-DESSUS
 SOLDADURAS EN LA PARTE SUPERIOR

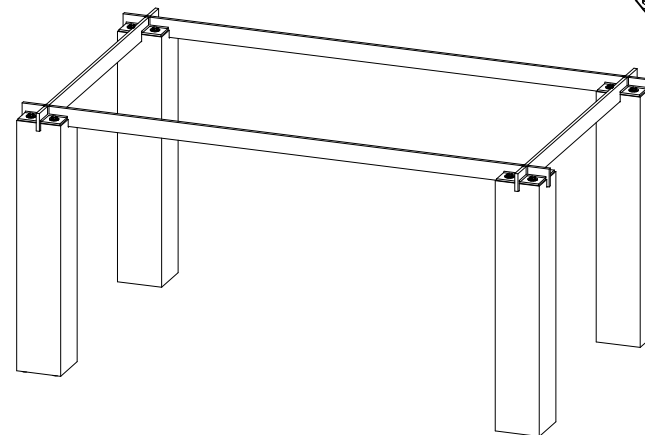

16 x

Assembly method for a table with legs

Principe d'assemblage d'une table à pattes

Instrucciones de ensamblaje de una mesa con patas



Do not climb on the table.
Risk of serious injuries.
Ne pas monter sur la table.
Risque de blessures graves.
No treparse sobre la mesa.
Riesgo de herirse gravemente.

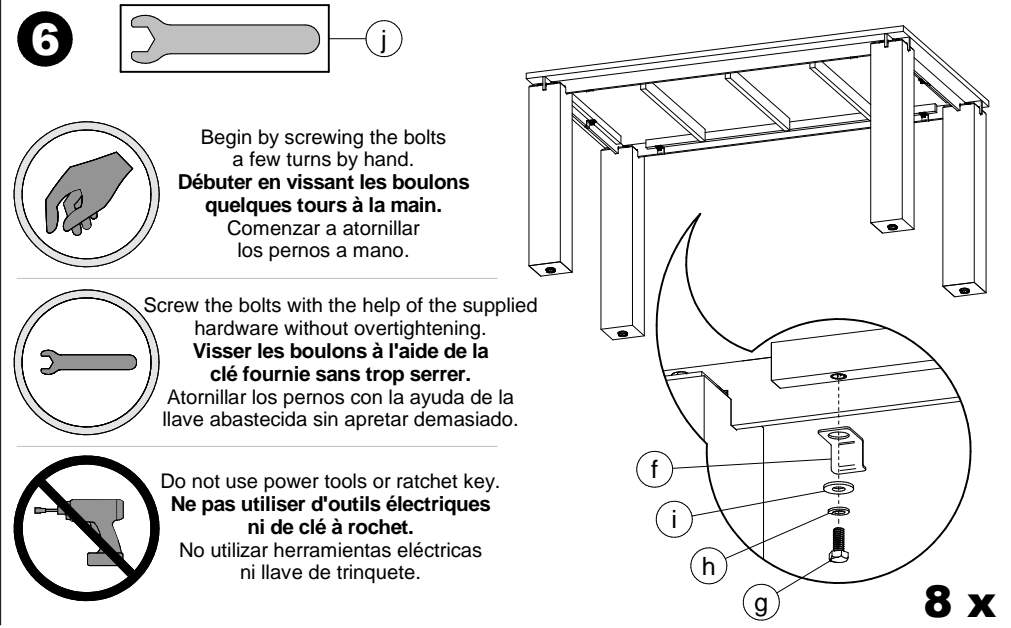
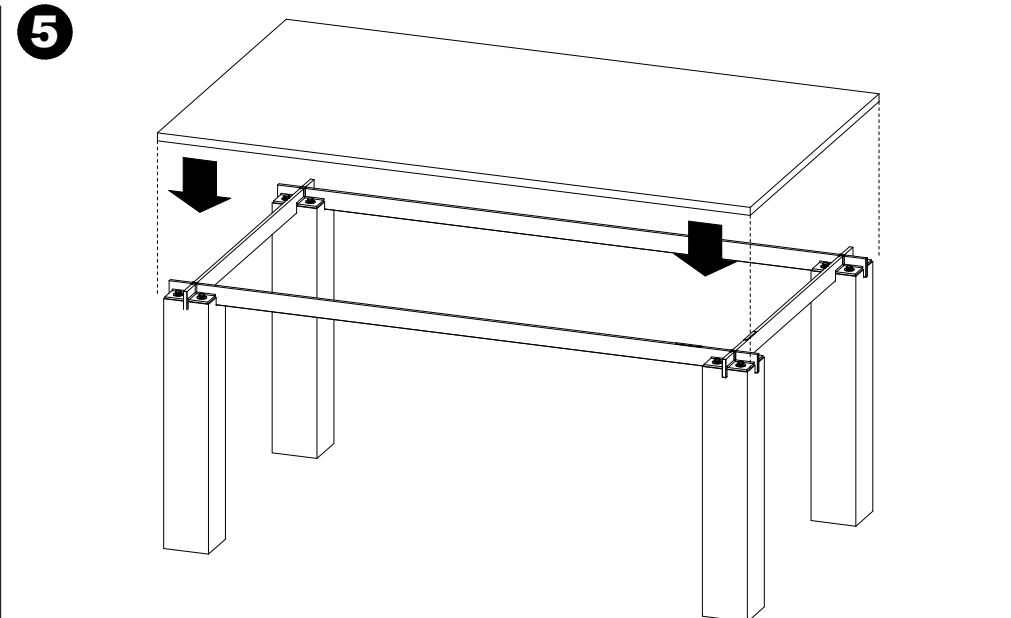
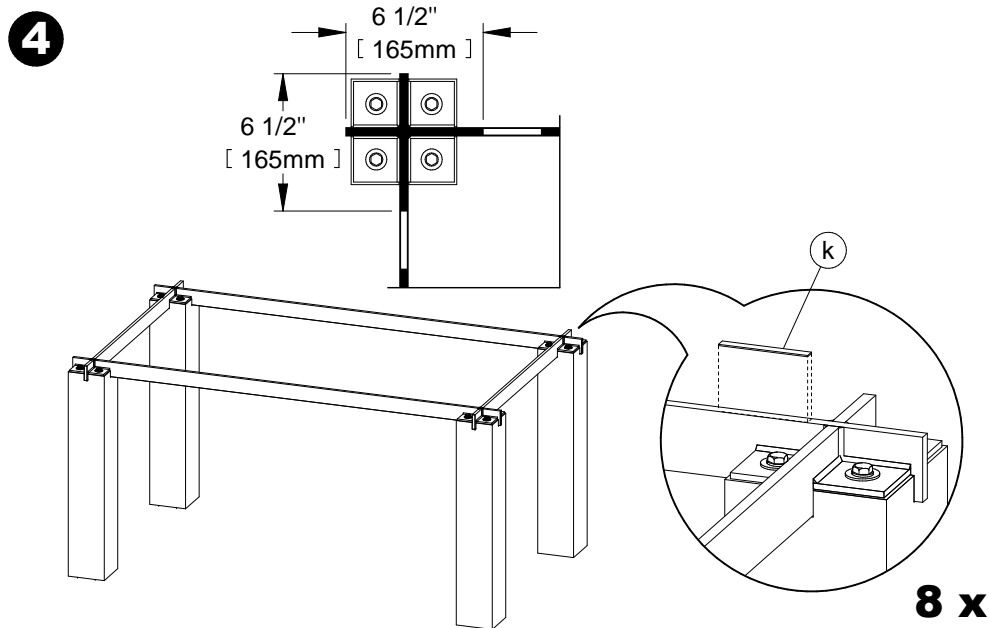
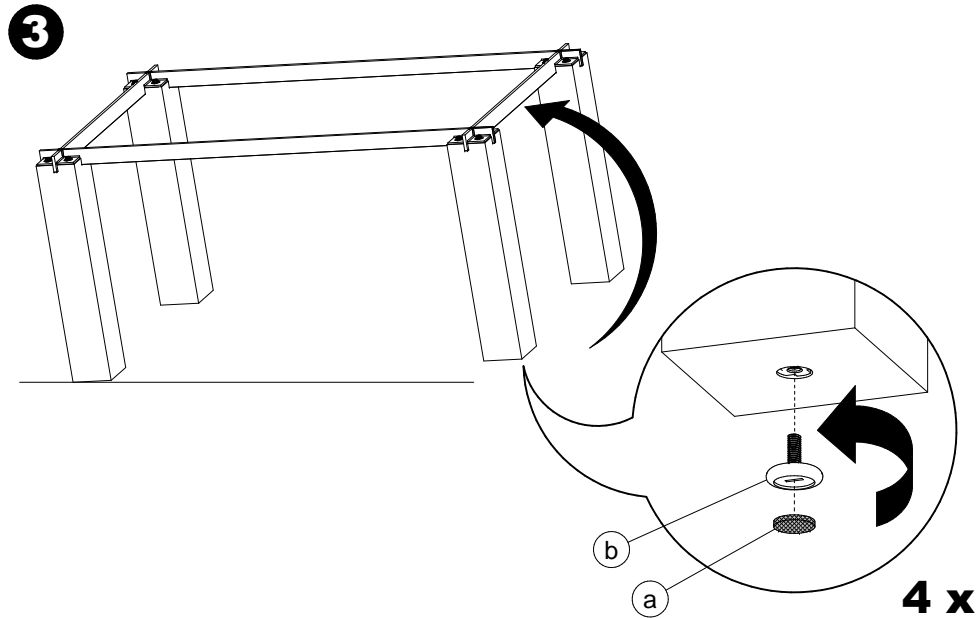

CODE PRODUIT SAC:	QUI2SACZ065	
CODE PRODUIT INFO-CLIENT:	FOP2INZTAB-1065	
REVISION:	P02	
DESCRIPTION	NOM	QTÉ
CLÉ 1/2" POUR BOLTS 5/16"	FOACLEZBOULON 1-2	1
BOULON HEX. 5/16-18 X 1 1/2" NOIR	FOAVISZBH5-16-18X1 1-2BL	16
BOULON HEX. 5/16-18 X 3/4"	FOAVISZBH5-16-18X3-4	8
LOCK WASHER 5/16 ZINC	FOAVISZLW 5-16	8
LOCK WASHER 5/16 NOIR	FOAVISZLW 5-16 BL	16
WASHER 5/16 (STD) ZINC	FOAVISZWAS3-8H 5-16B	8
WASHER 7/16H 3/8B NOIR	FOAVISZWAS7-16H 3-8B BL	16
CAOUTCHOUC 70MM X 8MM	FOPRUBZ7008	8
NIVELEUR DIA1 3/8"; 5/16-18X7/8"	QUIACCZ00701C	4
FEUTRE COLLANT DIA. 1"	QUIACCZFEUTREV23125	4
SUPPORT METAL	QUIACCZSUP-01	8