

Assembly method for a table with legs
Principe d'assemblage d'une table à pattes
Instrucciones de ensamblaje de una mesa con patas

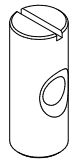

a 4 x

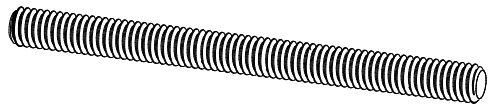

b 4 x

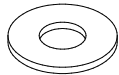

c 4 x



d 4 x



e 4 x

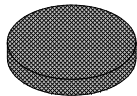

f 4 x



g 12 x



h 12 x

1

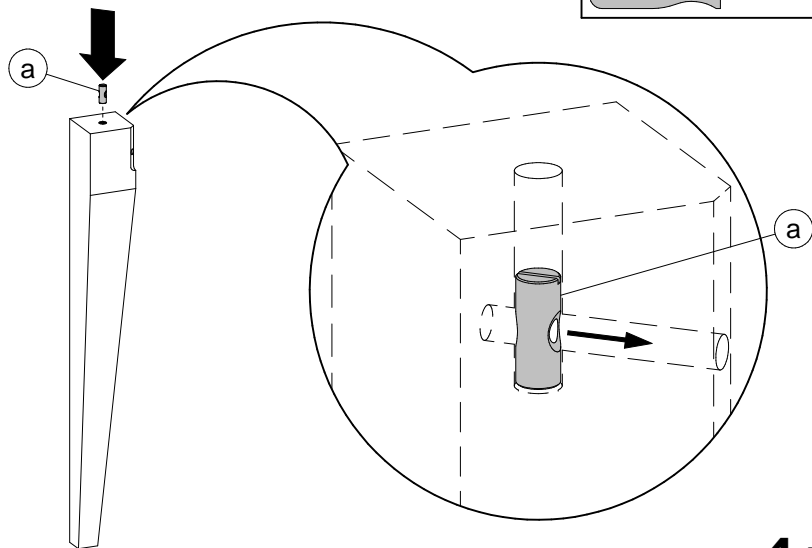

4 x

2

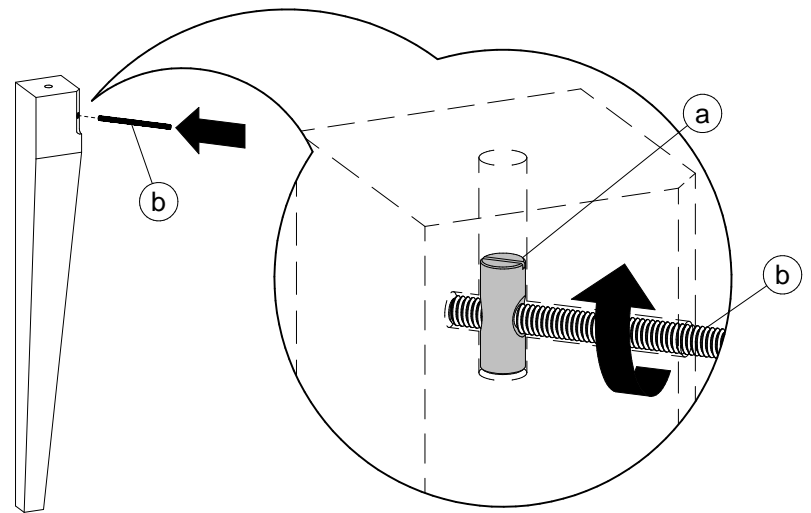

4 x

3

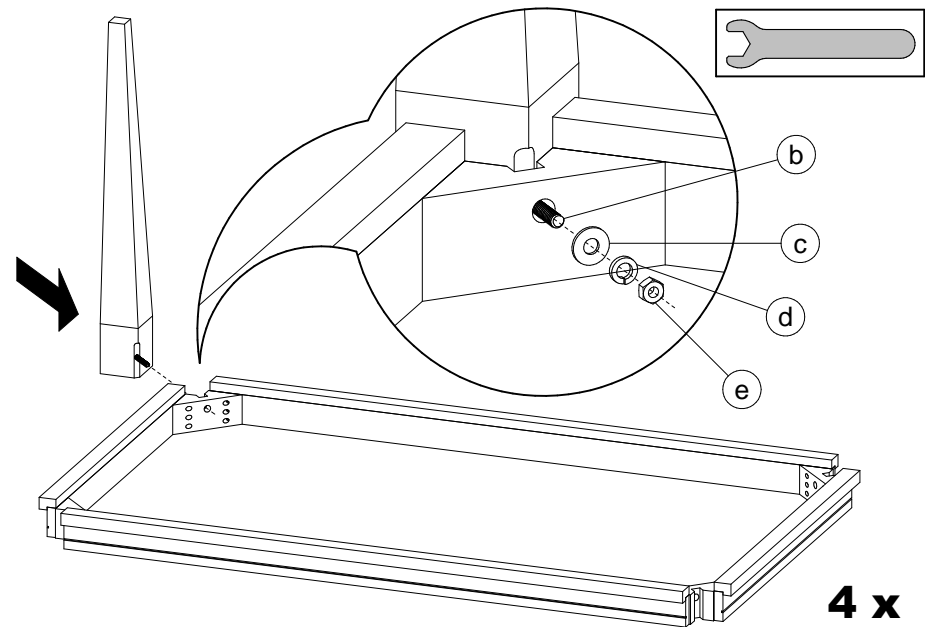

4 x

Assembly method for a table with legs

Principe d'assemblage d'une table à pattes

Instrucciones de ensamblaje de una mesa con patas



Do not climb on the table.
Risk of serious injuries.
Ne pas monter sur la table.
Risque de blessures graves.
No treparse sobre la mesa.
Riesgo de herirse gravemente.

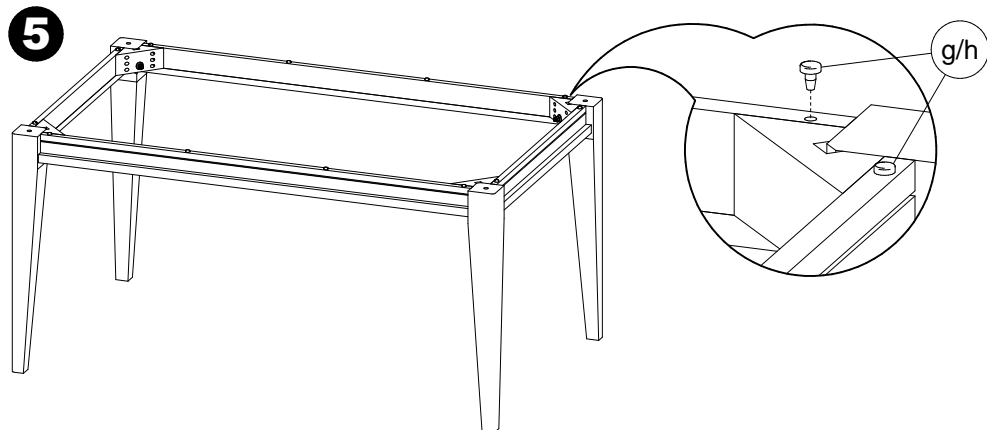
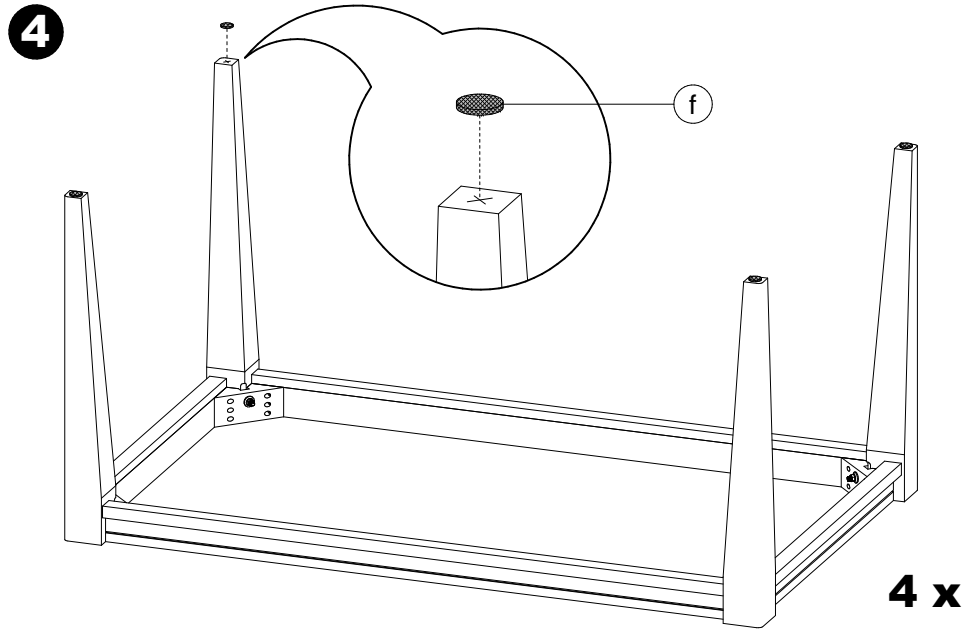

- Use transparent rubber pads for a clear glass top.
- **Utiliser les caoutchoucs transparents pour un dessus en verre clair.**
- Utilizar los cauchos transparentes para una parte superior de vidrio clara.
or / ou / o



- Use grey rubber pads for a colored glass top.
- **Utiliser les caoutchoucs gris pour un dessus en verre coloré.**
- Utilizar los cauchos grises para una parte superior de vidrio colorada.

- 6**
- Center the glass top. For a colored glass top, put the painted side facing down.
 - **Centrer le dessus en verre.**
 - **Pour un dessus en verre coloré, mettre la face peinte en dessous.**
 - Centrar la parte superior de vidrio.
 - Para una parte superior de vidrio colorada, colocar la cara pintada hacia abajo.

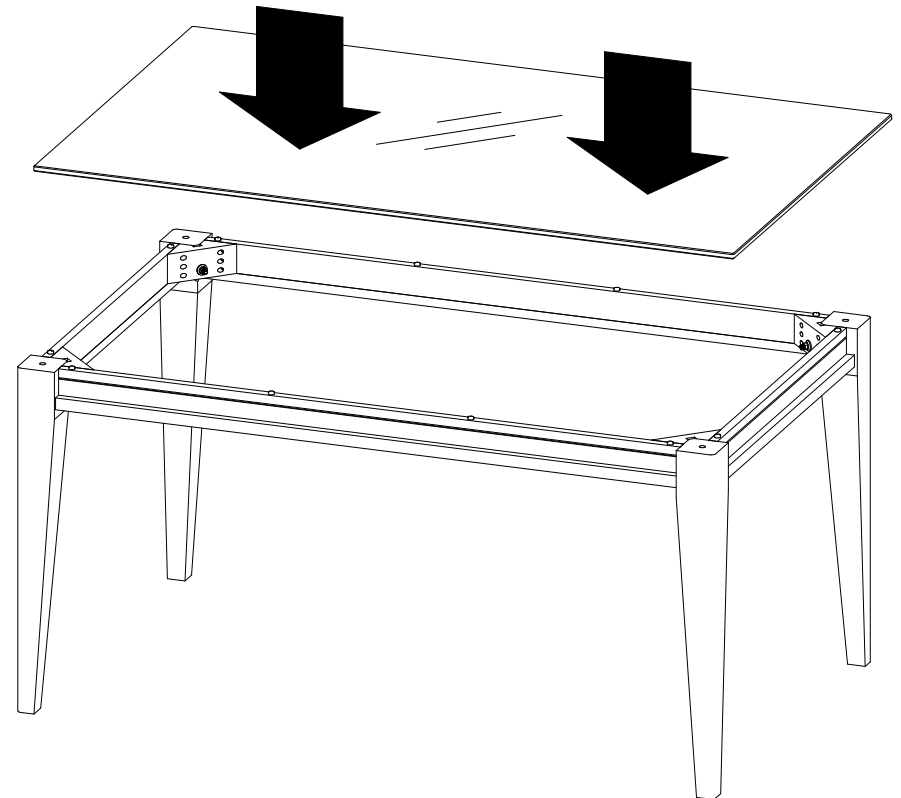

CODE PRODUIT SAC:	QUI2SACZ063	
CODE PRODUIT INFO-CLIENT:	FOP2INZTAB-1063	
REVISION:	P02	
DESCRIPTION	NOM	QTÉ
CAOUTCHOUC VITRE GRIS	FOAQUIZCP129105	12
BARREL NUT 5/16-18 X 30MM	FOAVISZCD5-16-18X30MM	4
ECROU 5/16-18 ZINC	FOAVISZHN5-16-18	4
LOCK WASHER 5/16 ZINC	FOAVISZLW 5-16	4
TIGE FILETÉE 5/16-18 X 4 3/4"	FOAVISZTF5-16-18X4 3-4	4
WASHER 5/16 (STD) ZINC	FOAVISZWAS3-8H 5-16B	4
FEUTRE COLLANT DIA. 1"	QUIACCZFEUTREV23125	4
CAOUTCHOUC VITRE CLAIR	QUIACCZP5090RUB	12